

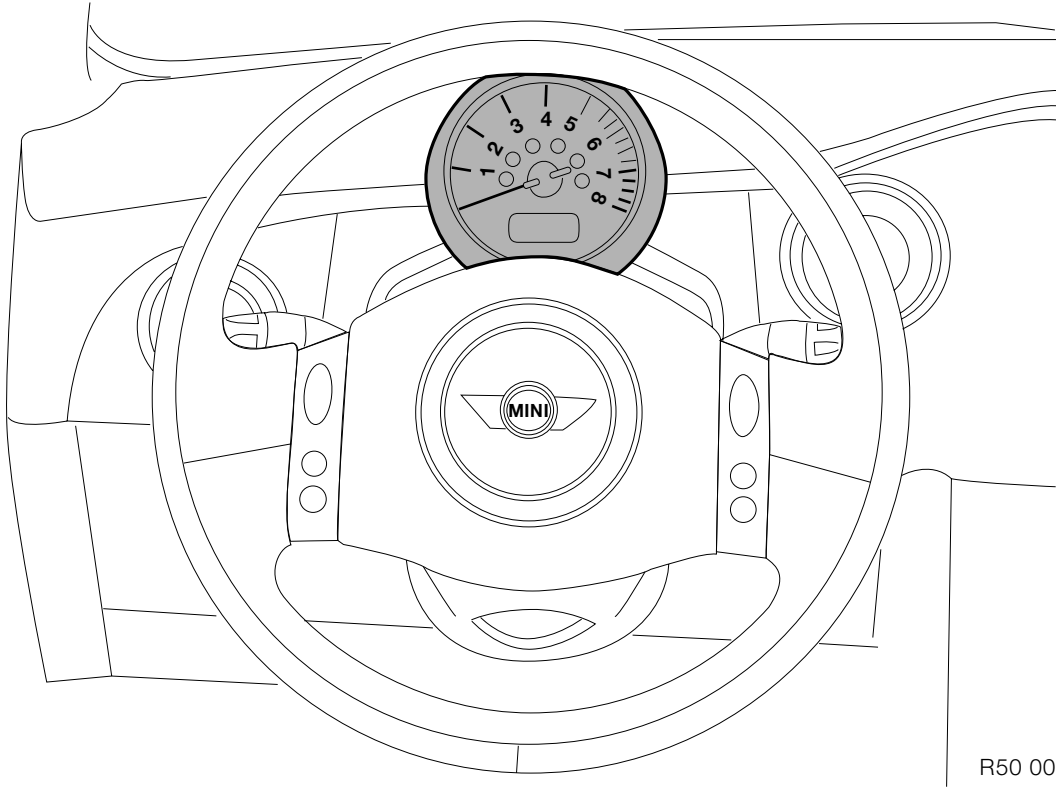

Parts and Accessories Installation Instructions



R50 0007 Z

Rev counter retrofit kit MINI (R50)

The installation time is approx. 1.5 hours, but this may vary depending on the condition of the car and the equipment in it.

Retrofit kit: 62 11 0 030 110

Contents

Section	Page
Important information	3
1. Preparations	4
2. Parts list	5
3. Installation and cabling diagram for retrofit wiring harness.	6
4. Rev counter wiring harness connection overview	7
5. To install and connect the rev counter wiring harness	8
6. To install the rev counter	10
7. Concluding work	11
8. Coding	12
9. Rev counter circuit diagram.	13

Important information

The retrofit kit is only for use within the dealership organisation.

Do not kink or damage the cables during the installation work since otherwise they may cause faults that can later only be identified by extensive additional work. The costs incurred as a result of this will not be reimbursed.

If the specified PIN chambers are occupied, bridges, double crimps or twin-lead terminals must be used.

Target group

The target group for these installation instructions is specialist personnel trained on MINI cars with specialist knowledge of vehicle electrical systems.

Work:

All servicing, repair and installation work on MINI cars is completed at your own risk.

All work is to be carried out using current MINI

- Repair manuals
- Circuit diagrams

in a rational order using the prescribed tools (special tools) and observing current health and safety regulations.

Required tools and equipment

Set of flat screwdrivers

Set of Philips screwdrivers

Torch

1/4 inch socket set

1/4 inch Torx socket set

Angle cutter

Combination pliers

1. Preparations

	TIS instruction No.
Disconnect the negative pole of the battery	12 00 ...
The following components must be removed first of all:	
Oddments box on the driver's side	
Top instrument panel cover	
Tachometer instrument panel	
Top and bottom steering column trims	

2. Parts list

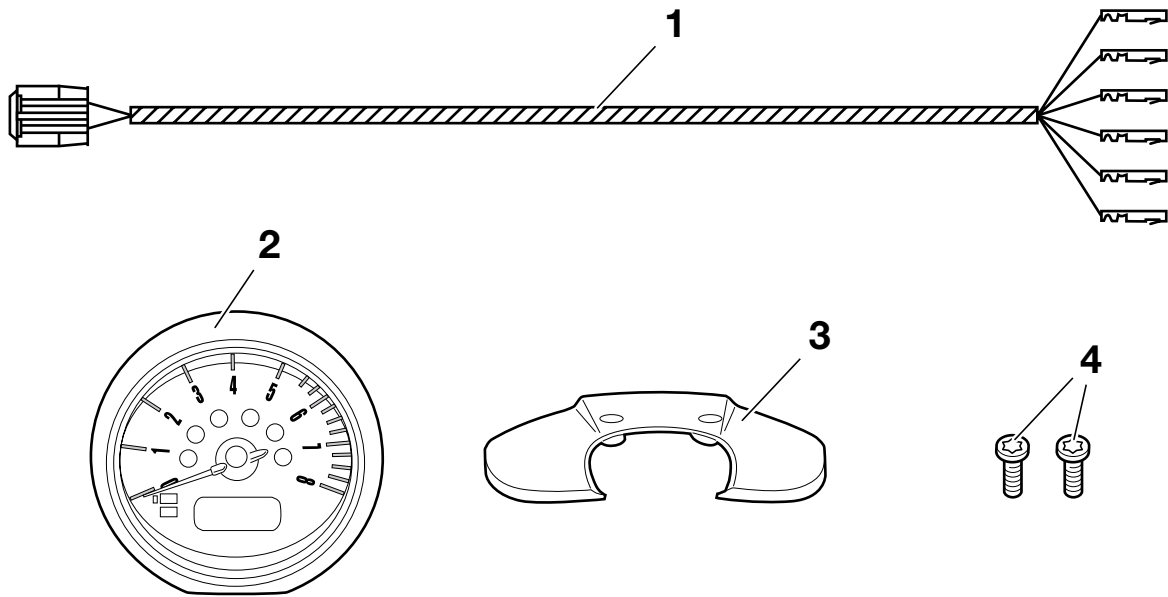

R50 0085 Z

Legend

- 1 Rev counter wiring harness **A**
- 2 Steering column rev counter
- 3 Cover
- 4 Torx screws (2x)

3. Installation and cabling diagram for retrofit wiring harness

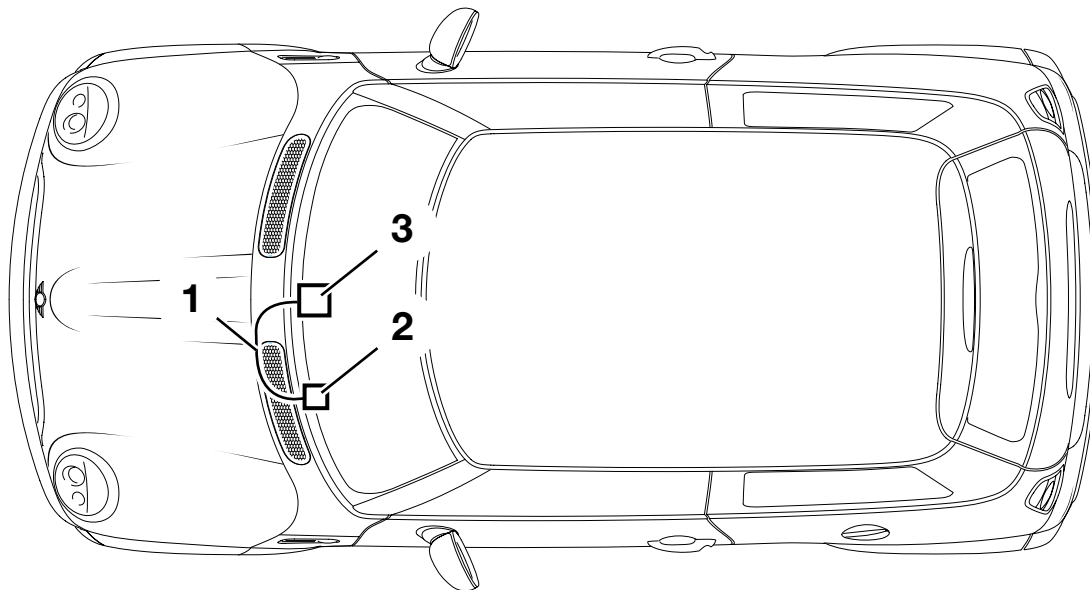

R50 0076 Z

Legend

- 1 Rev counter wiring harness **A**
- 2 Steering column rev counter
- 3 Tachometer instrument panel

4. Rev counter wiring harness connection overview

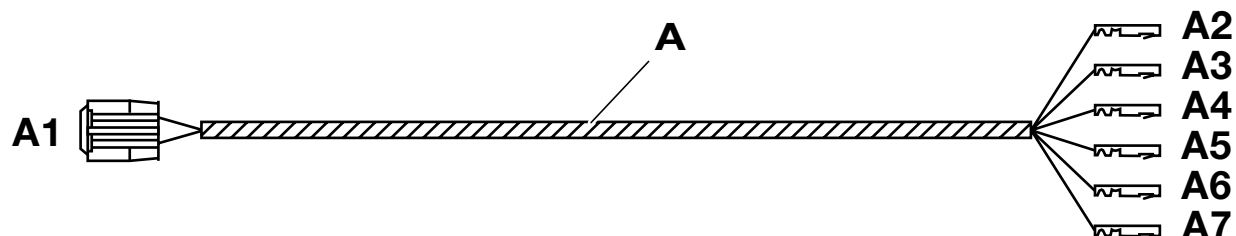

R50 0086 Z

Item	Description	Signal	Cable colour / Cross-section	Connection location in the car	Abbreviation / Slot
A	Rev counter wiring harness A	---	---	---	---
A1	Green 7-pin socket casing	---	---	To steering column rev counter	X11176
A2	Socket contact	Terminal 58g	GR/RT 0.35 mm ²	To tachometer instrument panel	X11175 PIN 2
A3	Socket contact	CAN H	GE/SW0.5 mm in diameter	To black 12-pin plug on the tachometer instrument panel	X11175 PIN 12
A4	Socket contact	CAN L	GE/BR0.5 mm in diameter	To black 12-pin plug on the tachometer instrument panel	X11175 PIN 6
A5	Socket contact	TRIP	BR0.35 mm in diameter	To black 12-pin plug on the tachometer instrument panel	X11175 PIN 8
A6	Socket contact	V battery	BL0.35 mm in diameter	To black 12-pin plug on the tachometer instrument panel	X11175 PIN 7
A7	Socket contact	Terminal 31	BR/SW0.35 mm in diameter	To black 12-pin plug on the tachometer instrument panel	X11175 PIN 1

5. To install and connect the rev counter wiring harness

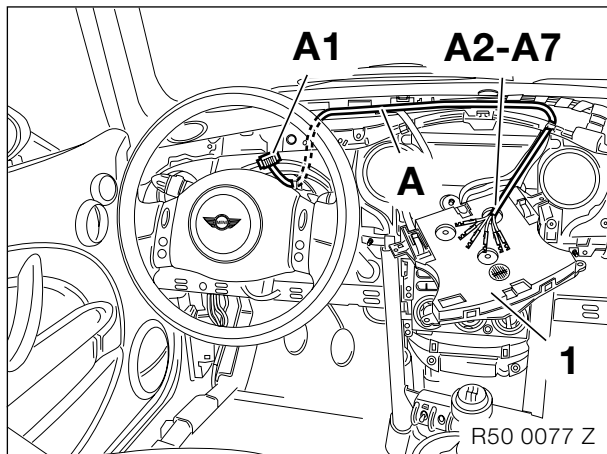

Lay wiring harness **A** as follows and secure it with cable ties:

- Branch **A1** to the installation site of the rev counter on the steering column
- Branches **A2 - A7** to the tachometer instrument panel (1)

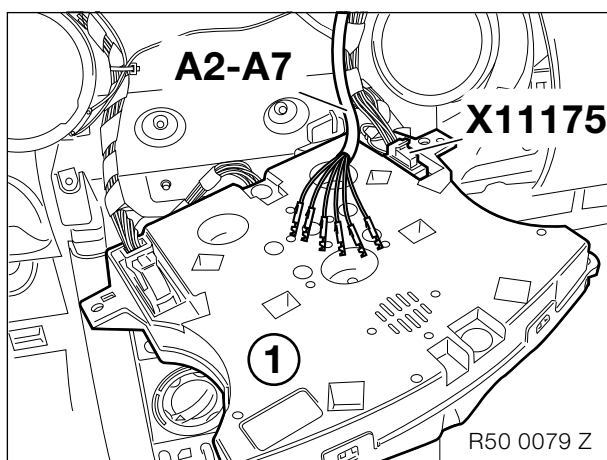

Connect branches **A2 - A7** as follows to plug **X11175** :

A2	GR/RT cable,	PIN 2
A3	GE/SW cable,	PIN 12
A4	GE/BR cable,	PIN 6
A5	BR cable,	PIN 8
A5	BL cable,	PIN 7
A7	BR/SW cable,	PIN 1

Connect plug **X11175** to the instrument cluster I (1).

6. To install the rev counter

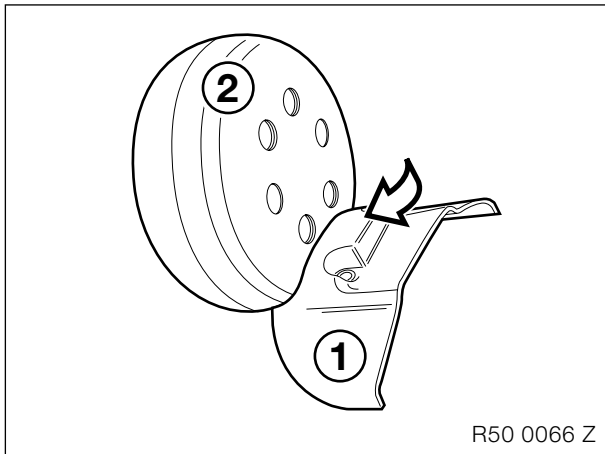

Place the cover (1) on to the steering column rev counter (2) as shown.

Refit the top and bottom steering column trims.

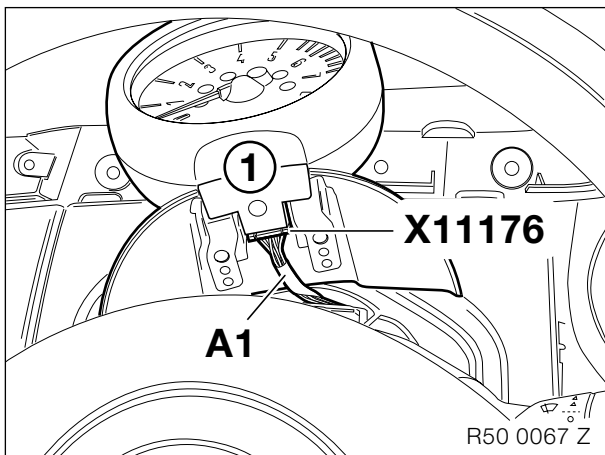

Connect branch **A1**, green 7-pin plug **X11176**, to the steering column rev counter (1).

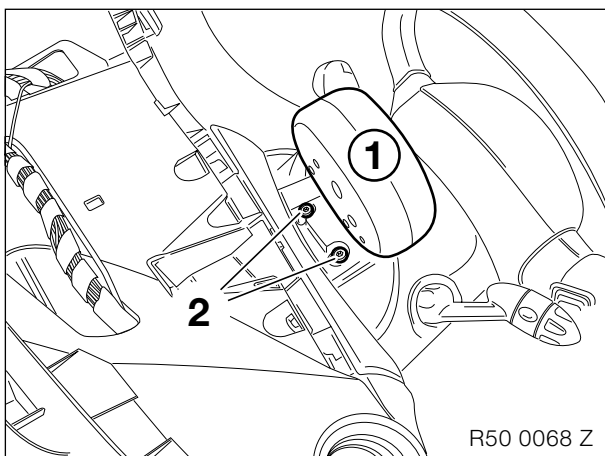

Screw the steering column rev counter (1) to the steering column using the Torx screws (2) provided.

7. Concluding work

- Connect the battery
- Complete the coding work (see section entitled "Coding")
- Conduct a function test
- Assemble the car again following the instructions to dismantle it in reverse order.

8. Coding

Retrofitting the steering column rev counter requires coding and must be coded using the “Retrofit rev counter” path using the MoDiC/DIS.

The coding work must be completed using CD version 26.0 (or higher).

After the coding procedure disconnect the car’s battery for at least 10 seconds, then reconnect it and conduct a function test.

9. Rev counter circuit diagram

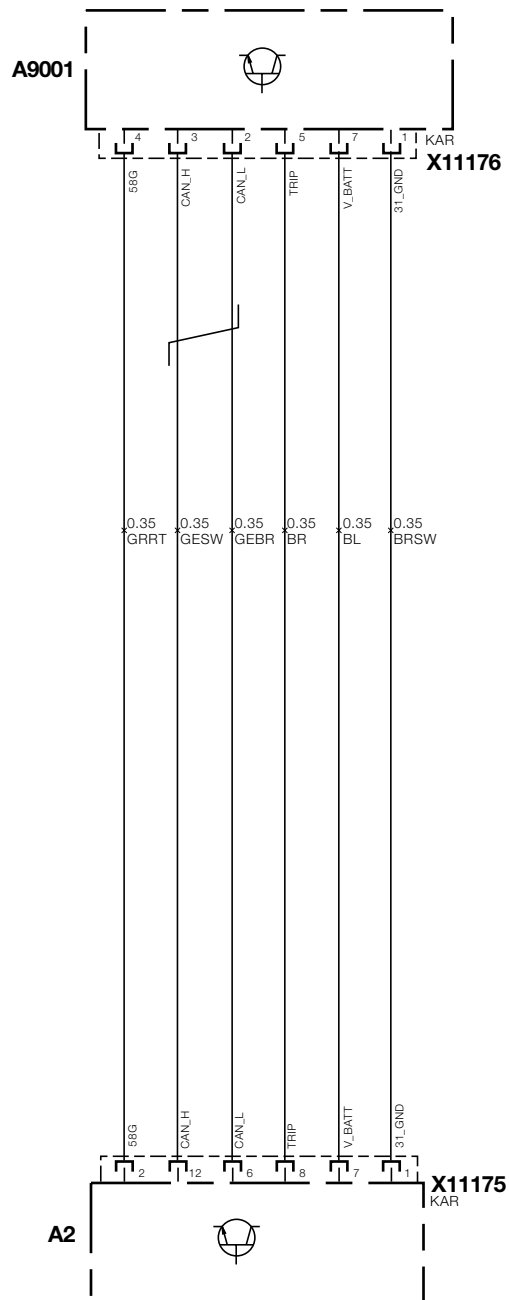

R50 0078 Z

9. Rev counter circuit diagram

Legend

A2 Tachometer instrument panel
A9001 Steering column rev counter

X11175 Tachometer instrument panel
X11176 Steering column rev counter

Cable colours

BR brown
GE yellow
SW black
RT red
GR grey
BL blue